

CISC 7332X T6

Reference Models and Example Networks

Hui Chen

Department of Computer & Information Science

CUNY Brooklyn College

Acknowledgement

- These slides are a minor revision of the slides provided by the publisher and the authors of the textbook

Outline

- Reference models
 - OSI model
 - TCP/IP model
 - Tanenbaum's 5-layer model
 - Critique of OSI and TCP/IP
- Overview of a few networks
 - The Internet
 - Mobile phone networks
 - Wireless LANs
 - Sensor networks

Reference Models

- Reference models describe the layers in a network architecture
 - OSI reference model
 - TCP/IP reference model
 - Model used for the textbook
 - Critique of OSI and TCP/IP

OSI Reference Model

- 7 layer model to connect different systems

7	Application	– Provides functions needed by users
6	Presentation	– Converts different representations
5	Session	– Manages task dialogs
4	Transport	– Provides end-to-end delivery
3	Network	– Sends packets over multiple links
2	Data link	– Sends frames of information
1	Physical	– Sends bits as signals

TCP/IP Reference Model

- A four layer model derived from experimentation; omits some OSI layers and uses the IP as the network layer

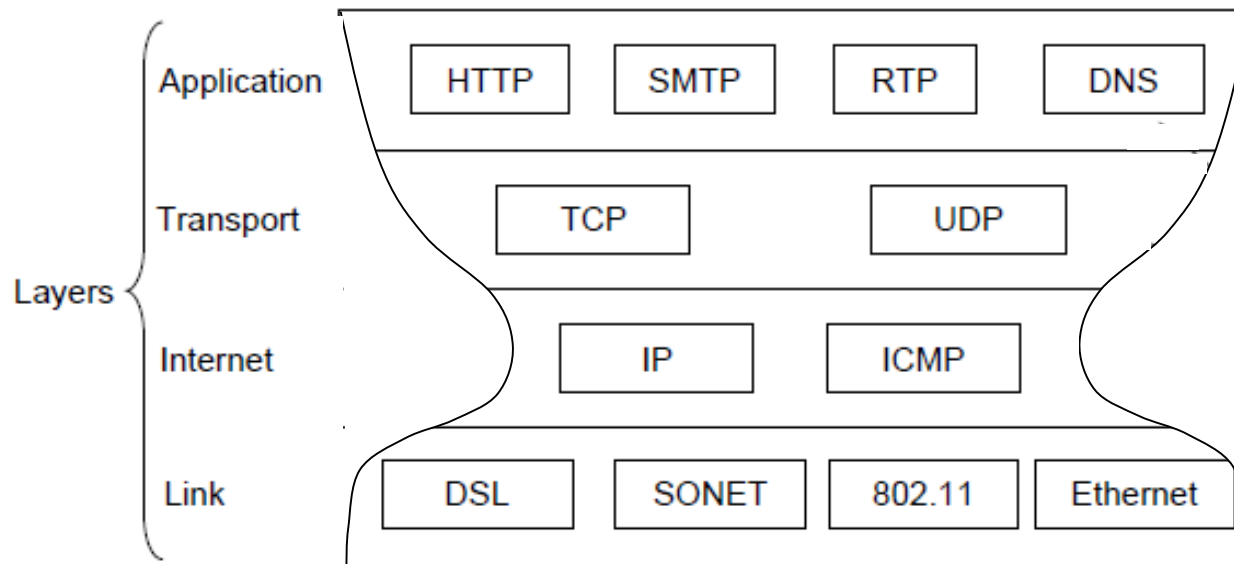

Tanenbaum's 5-Layer Model

- A 5-layer model based on TCP/IP

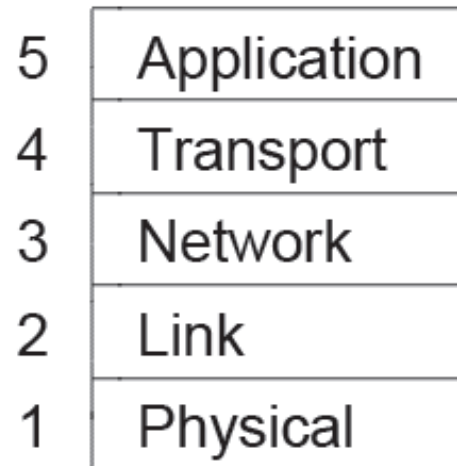

Critique of OSI & TCP/IP

- OSI

- (+) Very influential model with clear concepts
- (-) Models, protocols and adoption all bogged down by politics and complexity

- TCP/IP

- (+) Very successful protocols that worked well and thrived
- (-) Weak model derived after the fact from protocols

Example Networks

- The Internet
- Mobile phone networks
- Wireless LANs
- Sensor networks

History of The Internet

- ARPANET
- NSFNET
- The Internet

ARPANET

- A decentralized, packet-switched network based on Paul Baran's ideas.

Nodes are IMPs,
or early routers,
linked to hosts

56 kbps links

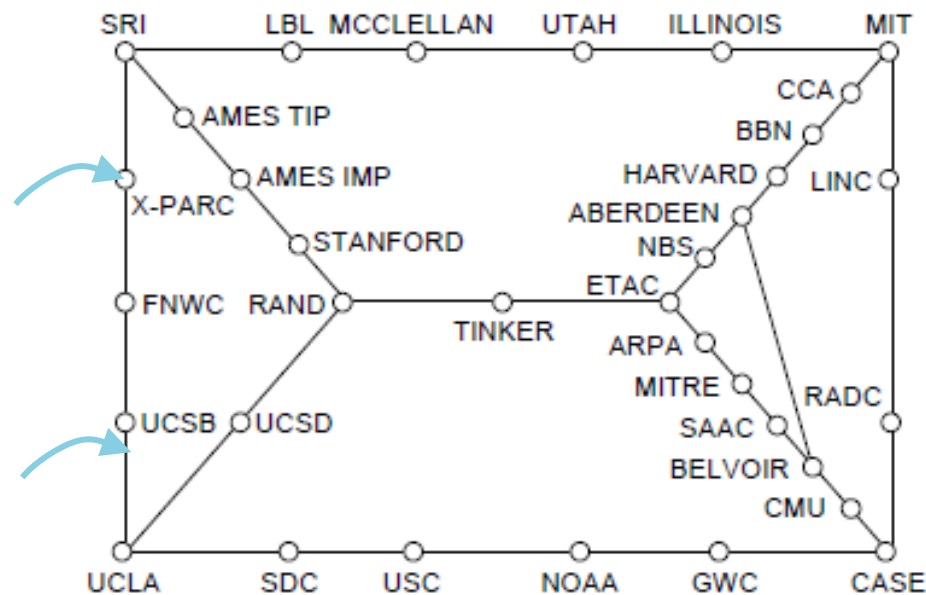

ARPANET topology in Sept 1972.

Centralized and Distributed

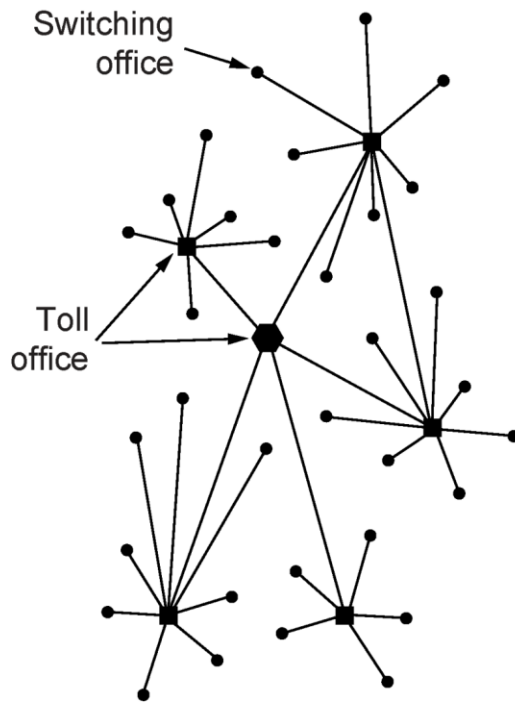

(a)

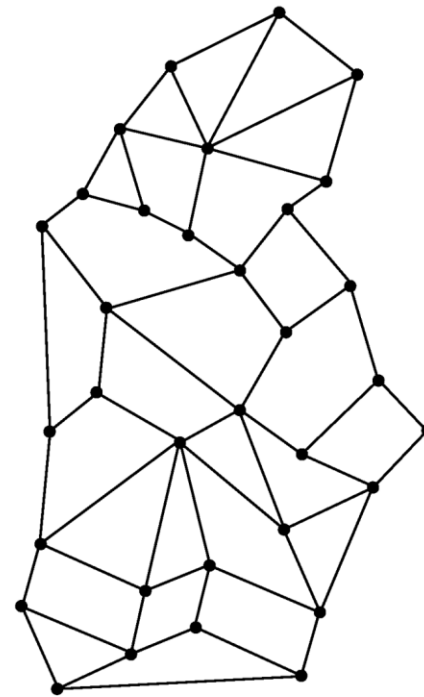

(b)

(a) Structure of the telephone system. (b) Baran's proposed distributed switching system.

NSFNET

- The early Internet used NSFNET (1985-1995) as its backbone; universities connected to get on the Internet

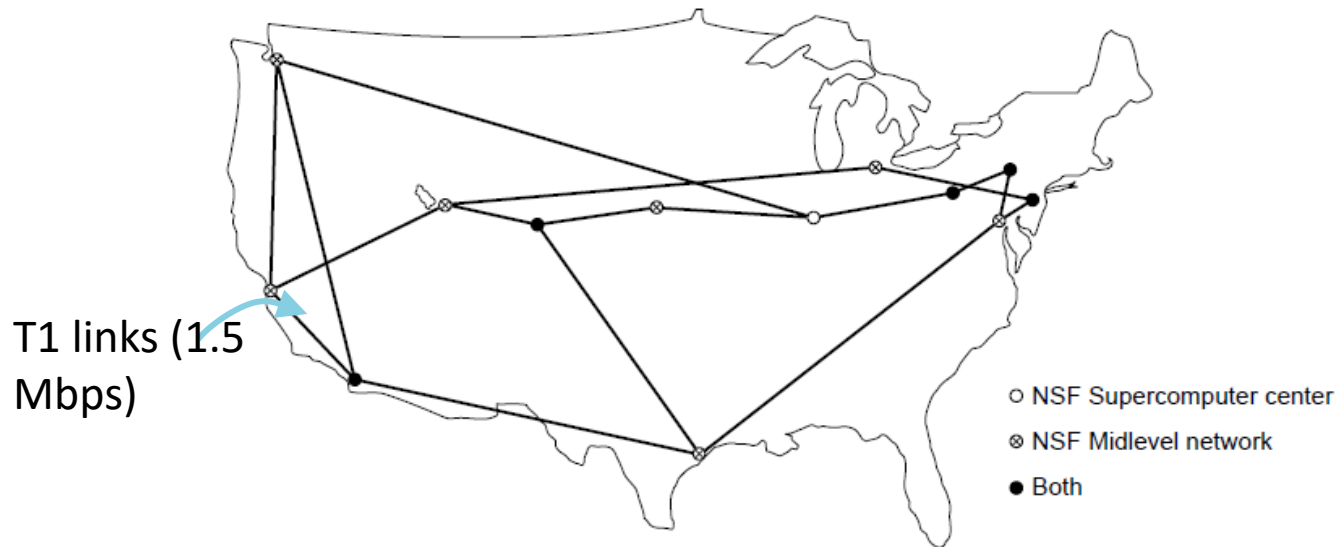

NSFNET topology in 1988

The Internet

- The modern Internet is more complex:
 - ISP networks serve as the Internet backbone
 - ISPs connect or peer to exchange traffic at IXPs
 - Within each network routers switch packets
 - Between networks, traffic exchange is set by business agreements
 - Customers connect at the edge by many means
 - Cable, DSL, Fiber-to-the-Home, 3G/4G wireless, dialup
 - Data centers concentrate many servers (“the cloud”)
 - Most traffic is content from data centers (esp. video)
 - The architecture continues to evolve

Architecture of the Internet

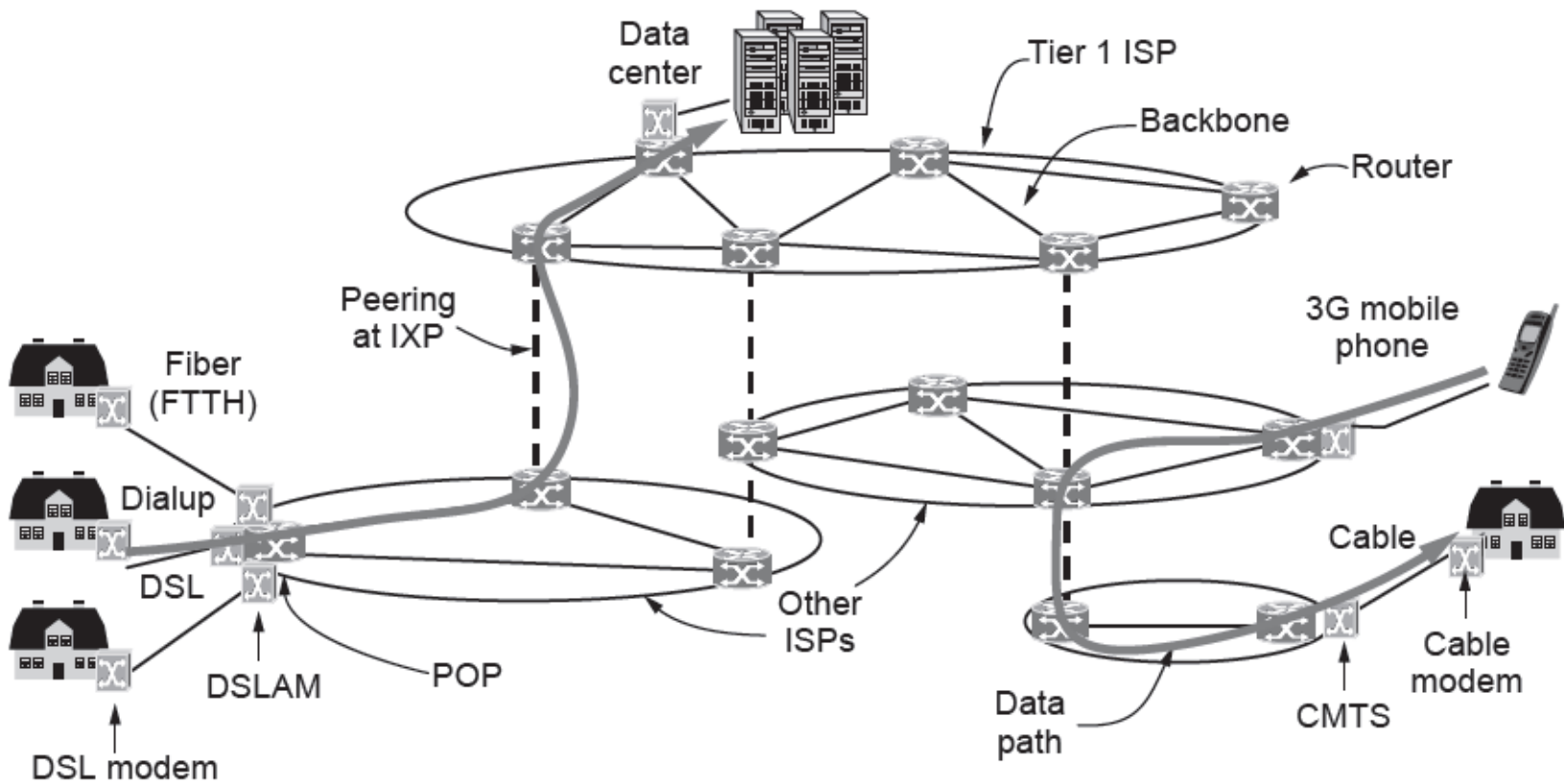

In-Class Exercise C02a-1

- (Derived from Question 18 in chapter 1)
We are considering the two networks in figures (a) and (b) in slide 12. How many bombs would it take to partition the nodes into two disconnected sets?
Assume any bomb wipes out a node and all of the links connected to it?

Mobile Phone Networks

- Mobile phone network is based on spatial cells; each cell provides wireless service to mobile phones via a base station

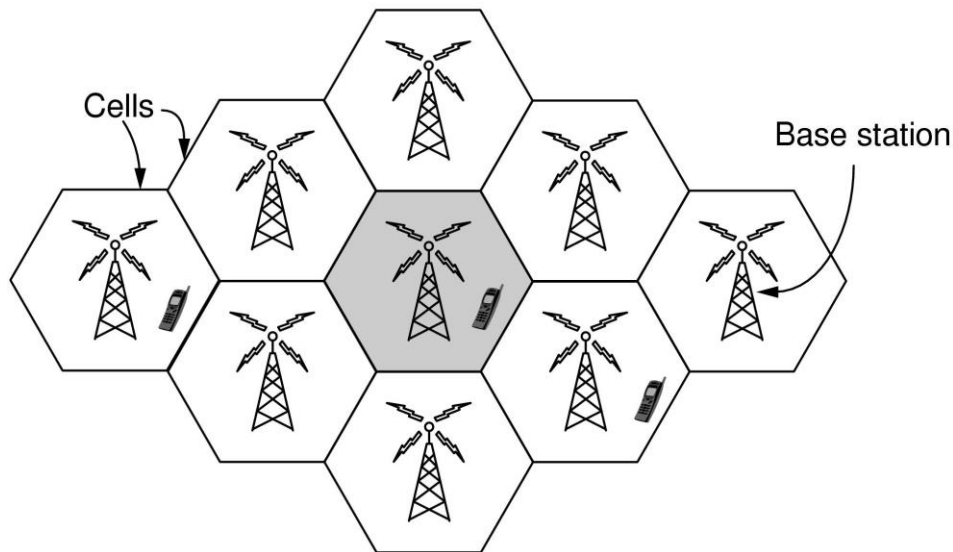

Overview of Mobile Phone Network

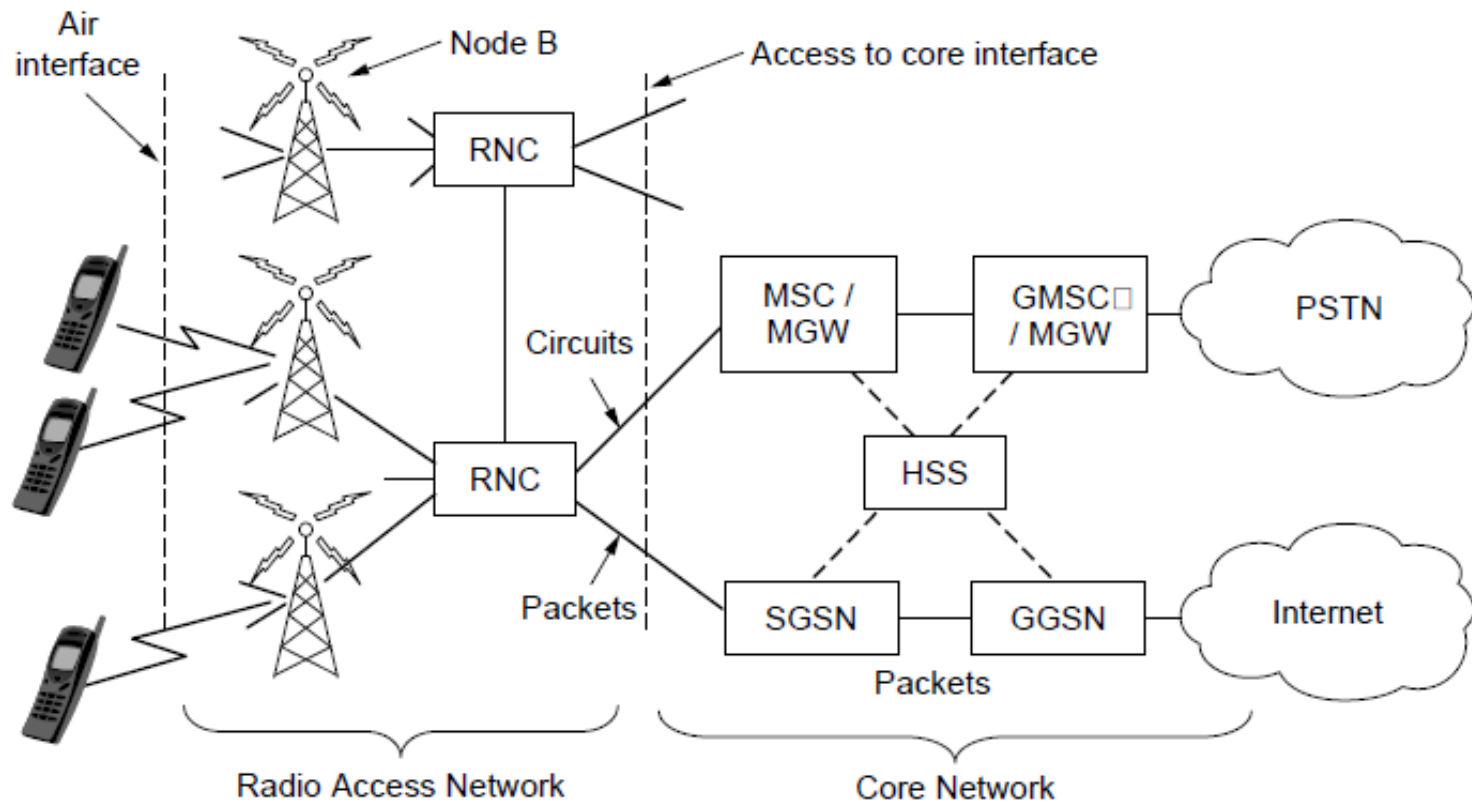

Handover

- Handover (or handoff): as mobiles move, base stations hand them off from one cell to the next, and the network tracks their location

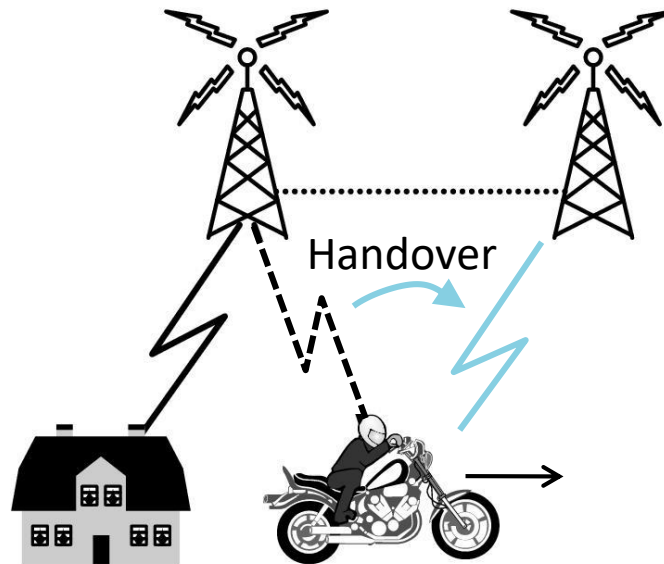

Wireless LANs

- In 802.11, clients communicate via an AP (Access Point) that is wired to the rest of the network.

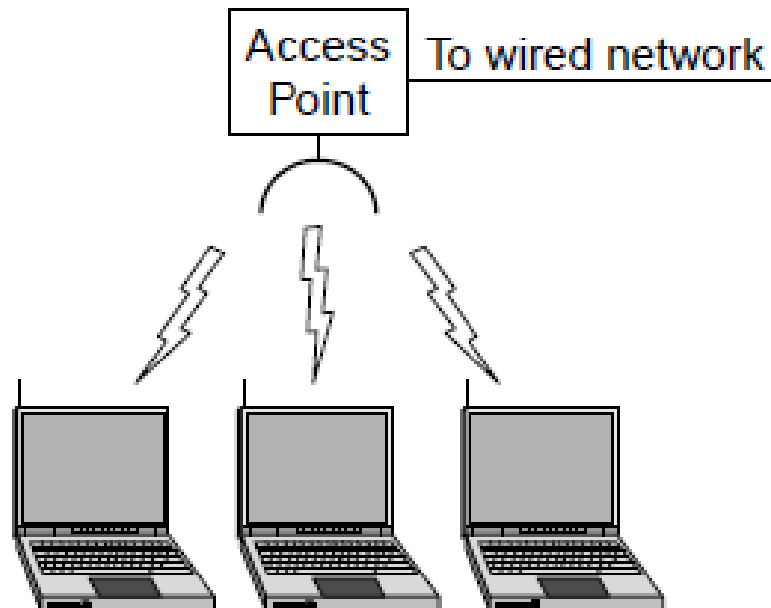

ISM Band and Challenges

- Signals in ISM band, such as, 2.4G and 5G in the US vary in strength due to many effects, such as multipath fading due to reflections
 - requires complex transmission schemes, e.g., OFDM

Multipath Fading

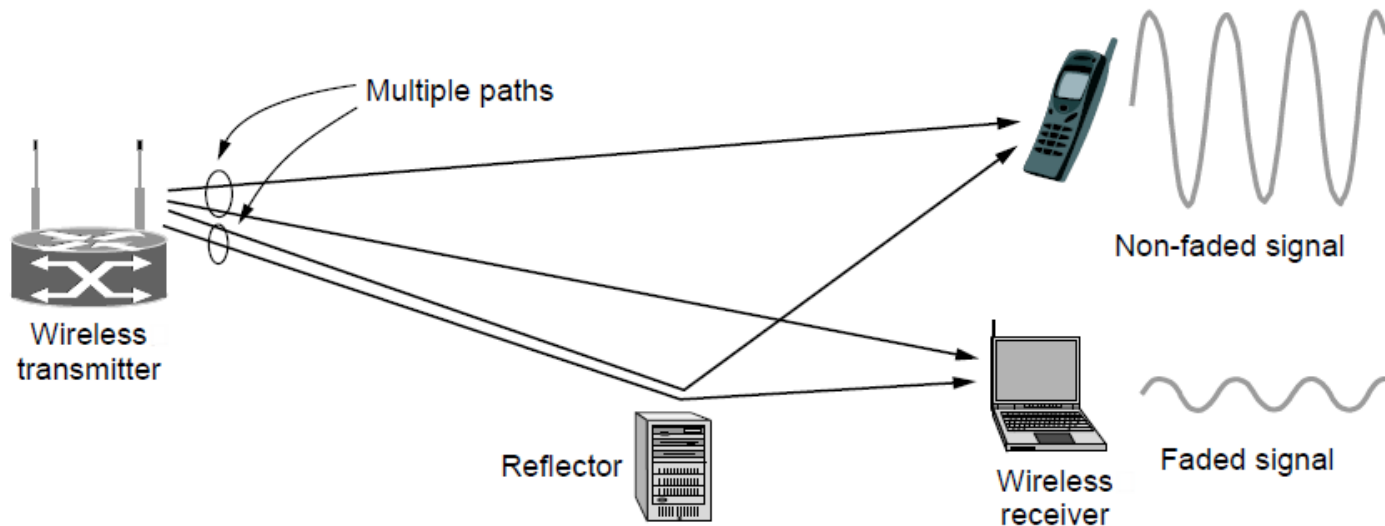

Radio Interference

- Radio broadcasts interfere with each other, and radio ranges may incompletely overlap
 - CSMA (Carrier Sense Multiple Access) design:

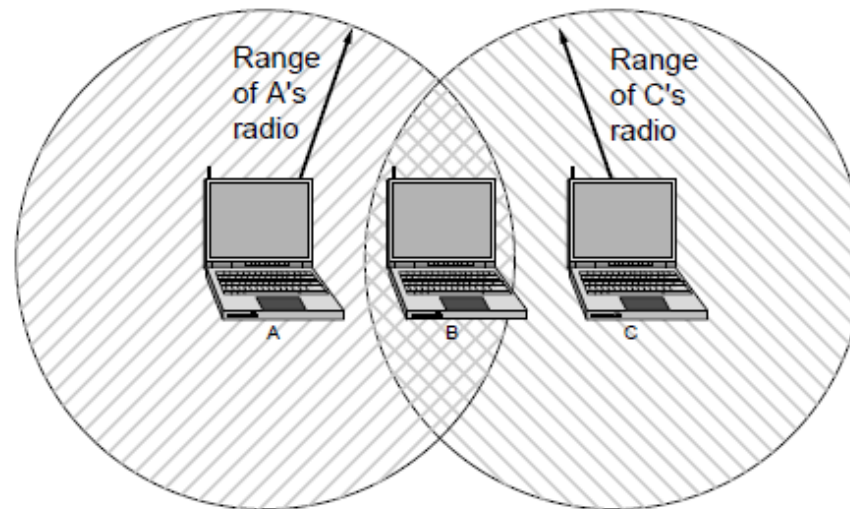

RFID and Sensor Networks

- Passive UHF RFID networks everyday objects

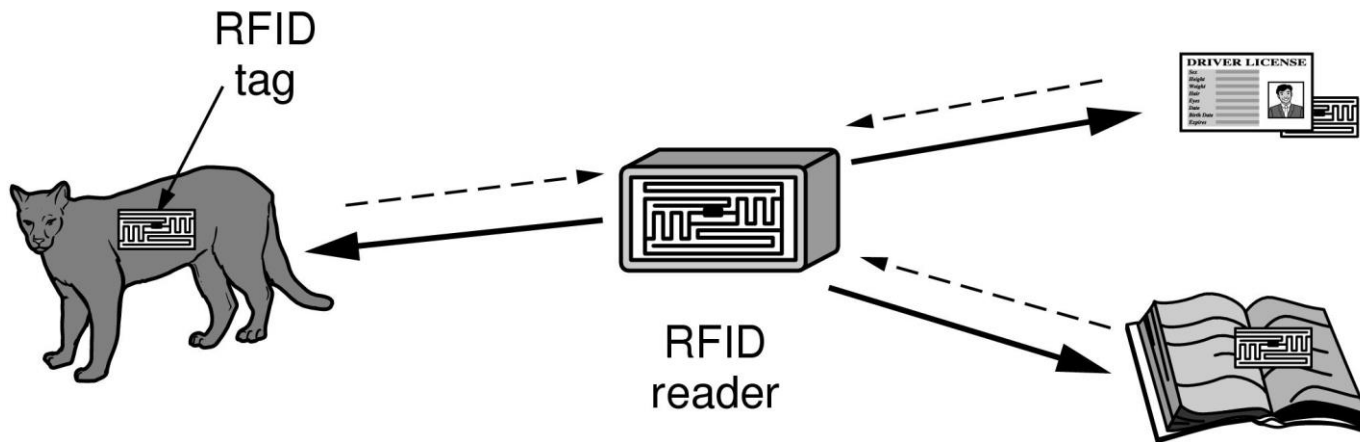

Passive RFID Tags and Readers

- Tags (stickers with not even a battery) are placed on objects
- Readers send signals that the tags reflect to communicate

Sensor Networks

- Sensor networks spread small devices over an area
 - Devices send sensed data to collector via wireless hops

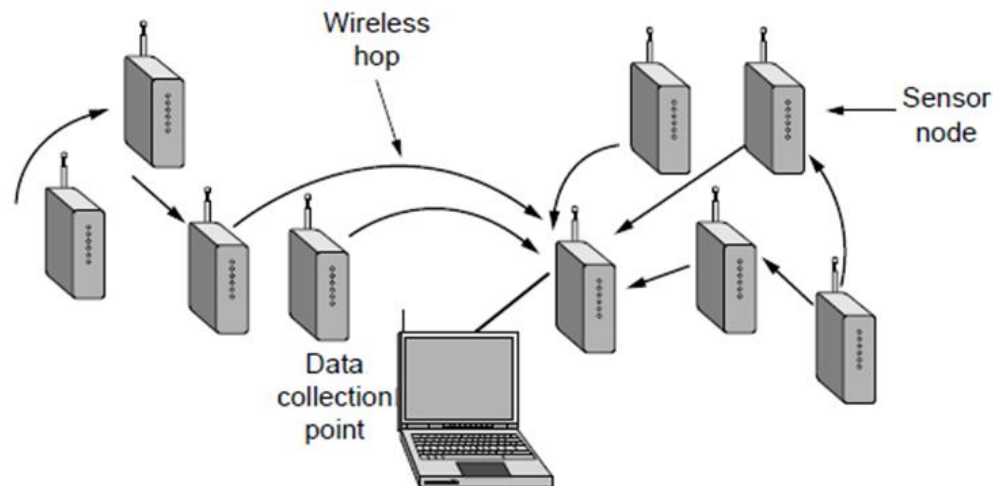

Network Standardization

- Standards define what is needed for interoperability
- Some of the many standards bodies:

Body	Area	Examples
ITU	Telecommunications	G.992, ADSL H.264, MPEG4
IEEE	Communications	802.3, Ethernet 802.11, WiFi
IETF	Internet	RFC 2616, HTTP/1.1 RFC 1034/1035, DNS
W3C	Web	HTML5 standard CSS standard

Questions?

- Reference models
- Overview of a few networks

In-Class Exercise C02a-2

- (Derived from Question 16 in chapter 1)
A system has 5-layer protocol hierarchy. Applications generate message of length 1500 bytes. At each of the layers, a 40-byte header is added. What fraction of the network bandwidth is filled with headers?