

CISC 7332X T6
C12a: LAN Switching

Hui Chen

Department of Computer & Information Science

CUNY Brooklyn College

Acknowledgements

- Some pictures used in this presentation were obtained from the Internet
- The instructor used the following references
 - Larry L. Peterson and Bruce S. Davie, *Computer Networks: A Systems Approach*, 5th Edition, Elsevier, 2011
 - Andrew S. Tanenbaum, *Computer Networks*, 5th Edition, Prentice-Hall, 2010
 - James F. Kurose and Keith W. Ross, *Computer Networking: A Top-Down Approach*, 5th Ed., Addison Wesley, 2009
 - Larry L. Peterson's (<http://www.cs.princeton.edu/~llp/>) Computer Networks class web site

Ethernet LAN: How to Expand?

- Expand an Ethernet local area network (LAN)
 - Repeaters
 - Bridges
 - Switches

Repeaters

- Devices in physical layer
- Receive, amplify (regenerate), and retransmit signal in both directions.
- Example: Ethernet repeaters

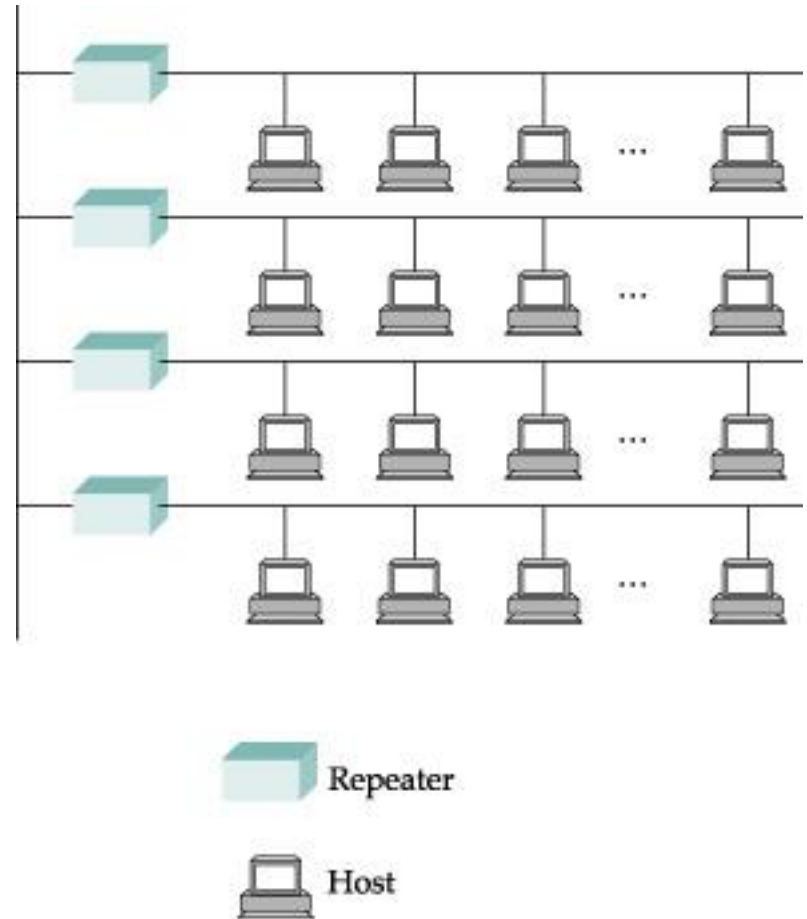

Bridges

- Devices in data link layer
- In promiscuous mode
- Forward packets/frames to either connected networks
- Example: Ethernet bridges

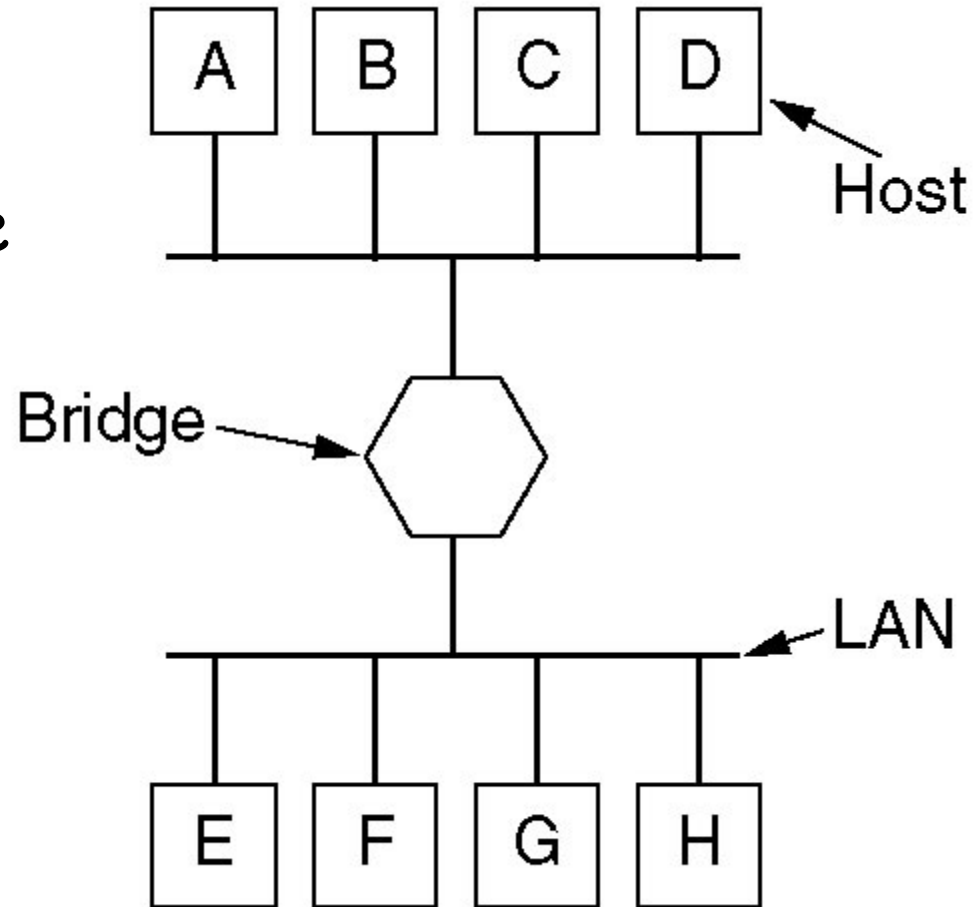

Ethernet Switches: Learning Bridges

- Do you actually need to forward every frames when

- $A \rightarrow B$?
- $A \rightarrow X$?

- Improvement

- Do not forward unnecessarily
- Relying on a **forwarding table** at each switch

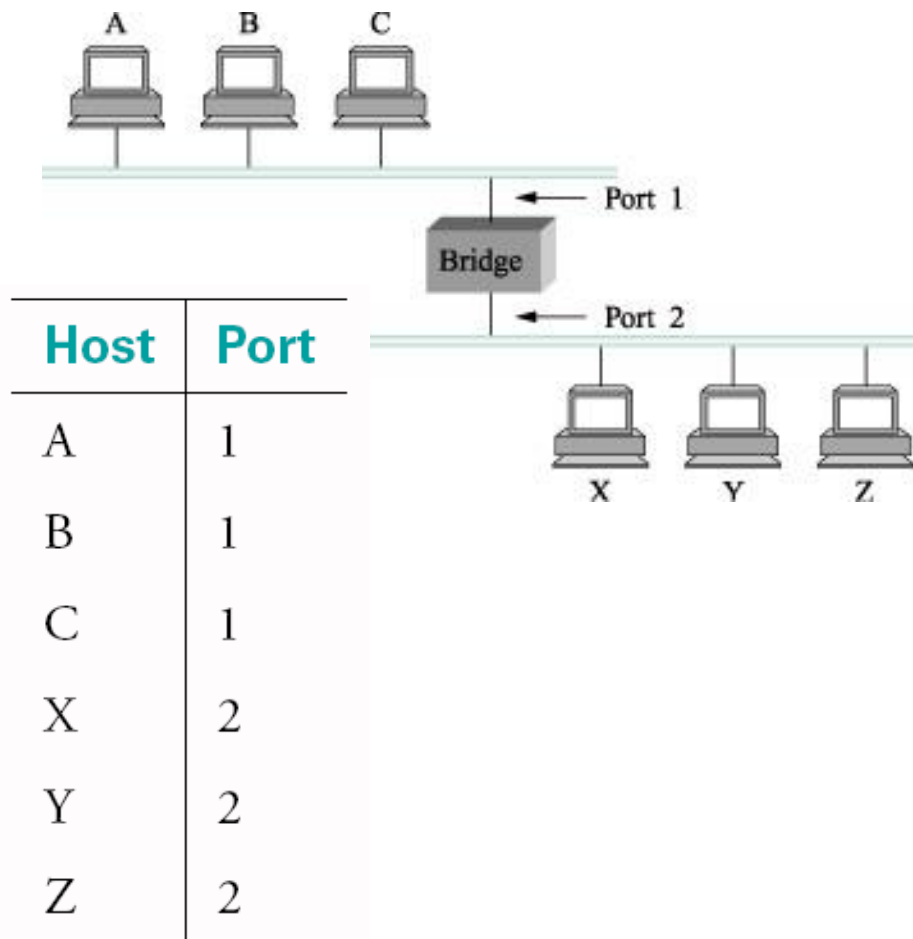

Forwarding Algorithm

- Destination address in frame header indicates which host a frame is addressed to
- Source address in frame header indicates which host a frame is originated
- Each bridge maintains a "forwarding" table
- Algorithm
 - On receiving a frame (*src, dst, receiving port*), look up *dst* in the forwarding table
 - If *dst* is found
 - If port in forwarding table = receiving port, do not forward;
 - otherwise, forward to the forwarding port
 - Otherwise, forward to all ports

Host	Port
A	1
B	1
C	1
X	2
Y	2
Z	2

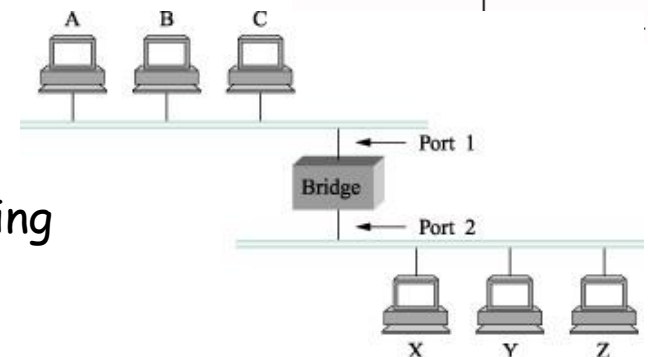

Exercise C12a-1

- Build a complete “forwarding” table for the Ethernet switch

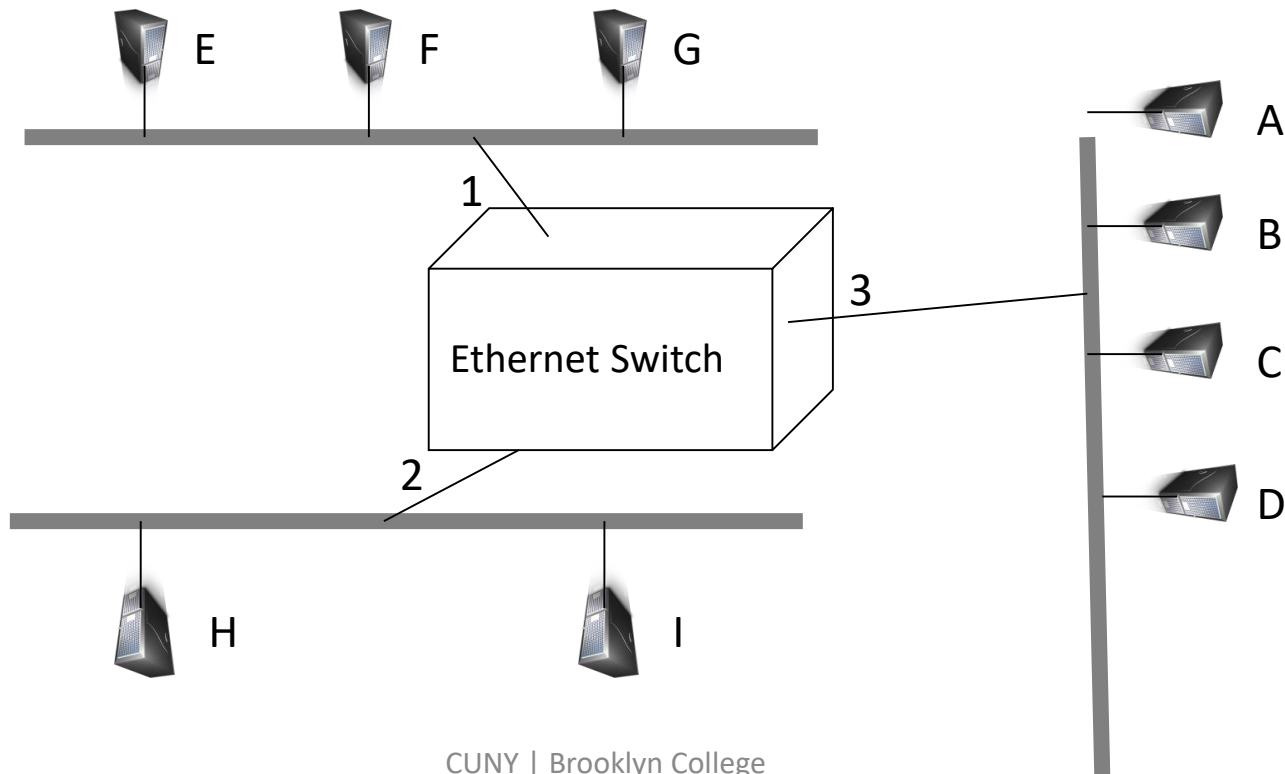

Questions?

- Packet switching in extended LAN
- Forwarding table and forwarding algorithm in extended LAN

Ethernet Switches: Learning Bridges

- Improvement
 - Forwarding table
 - Do not forward unnecessarily to receiving port.
- How to maintain the table?
 - Manually?
 - Automatically?
- Learning bridges
 - automatically maintain the table without human intervention → "learning" from received frames → Ethernet switches = Learning bridges
- How does it learn?

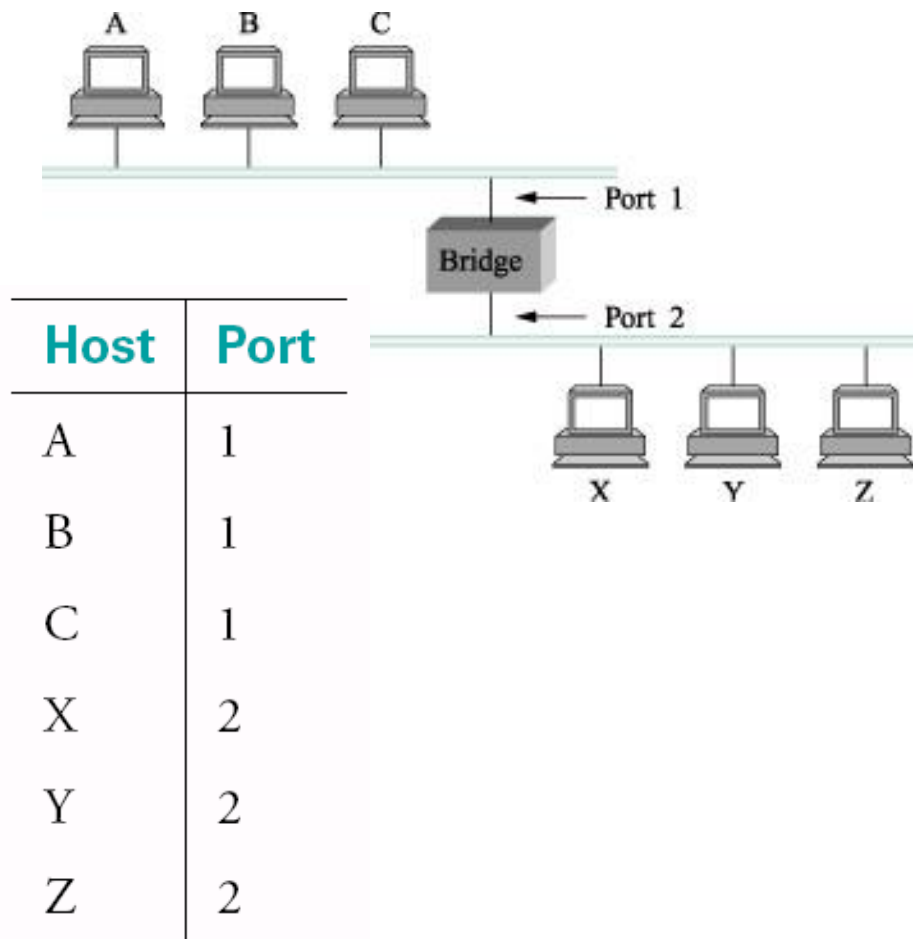

Ethernet Switches: Learning from Received Frame

- From a received frame, an Ethernet switch knows
 - Destination address and source address
- Receiving port number on the switch



Learning Bridges: Learning Algorithm

- Destination address in frame header indicates which host a frame is addressed to
- Source address in frame header indicates which host a frame is originated
- Each bridge maintains a "forwarding" table, initially empty
- Algorithm
 - On receiving a frame (*src*, *dst*, *receiving port*), look up *src* in the forwarding table
 - If *src* is not found
 - Insert (*src*, receiving port number) to the forwarding table

Host	Port
A	1
B	1
C	1
X	2
Y	2
Z	2

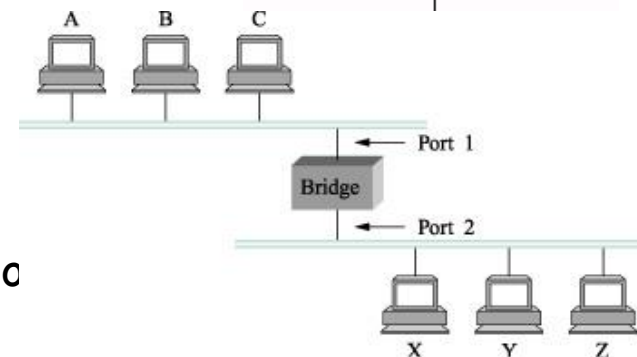

Learning Algorithm: Example

- Describe the table built by the switch as the following frames arrives
 - Starting with the table as follows

Host	Port
B	3
 - The following frames (indicated by sending hosts) are received by the bridge as time goes
 - I, H, B, F (reads, first I, then H, then B, and then F)
 - Please draw four tables to show the resulting table after each frame is processed

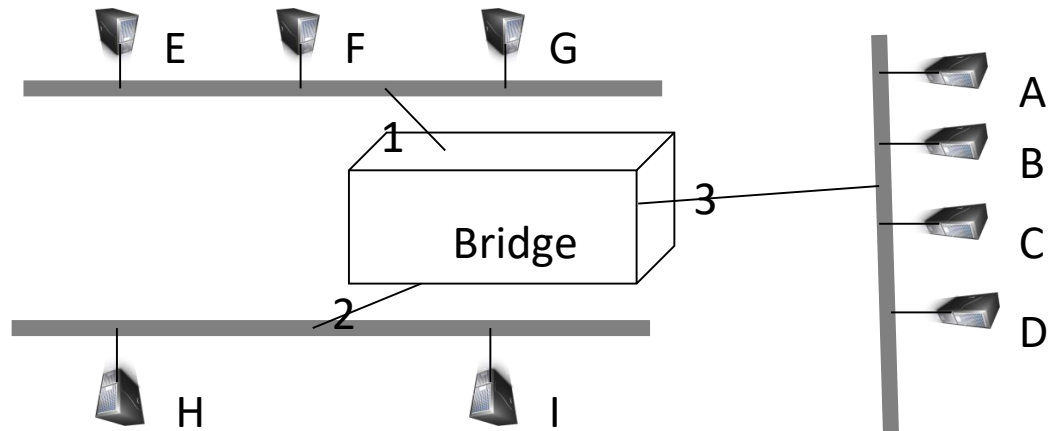

Learning Algorithm: Example: Example: Answer

0. Initial table

Host	Port
B	3

1. Frame sent from Host I arrives

Host	Port
B	3
I	2

2. Frame sent from Host H arrives

Host	Port
B	3
I	2
H	2

3. Frame sent from Host B arrives

Host	Port
B	3
I	2
H	2

4. Frame sent from Host F arrives

Host	Port
B	3
I	2
H	2
F	1

Example: Question 1

0. Initial table

Host	Port
B	3

Q: which hosts will see the frame sent from Host I?

Example: Question 2

0. Initial table

Host	Port
B	3

Q: which hosts will see the frame sent from Host B?

1. Frame sent from Host I arrives

Host	Port
B	3
I	2

2. Frame sent from Host H arrives

Host	Port
B	3
I	2
H	2

Exercise C12a-2

- Starting with an empty forwarding table at each switch, step-by-step build a forwarding table for each switch of the Ethernet shown as the following transmissions happen
 - A sends to C; C sends to A; E sends to I; I sends to E; E sends to B

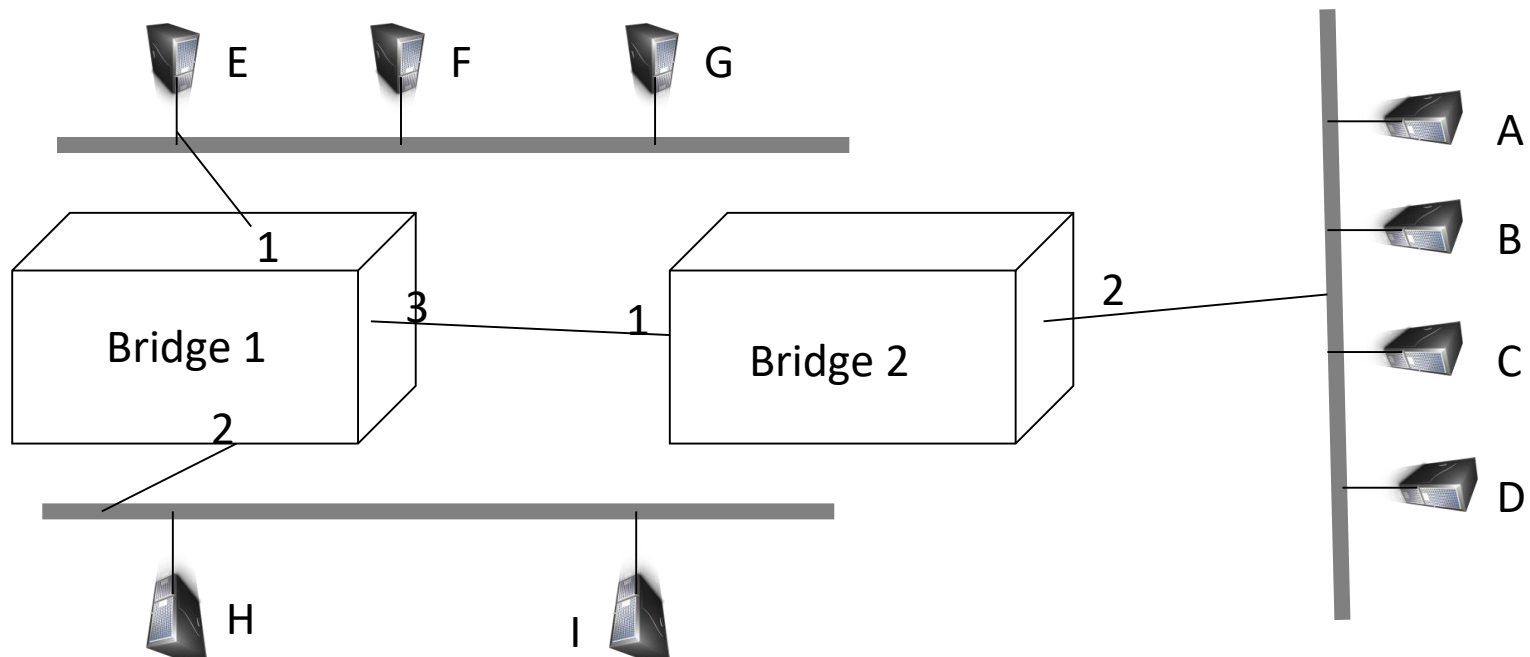

Questions?

- Learning algorithm of learning bridge/switch in extended LAN